

PT 20Li

Lithium Powered Pallet Truck

The PT20Li power pallet truck is equipped with 1.4KW three-phase AC drive motor , high power 2.2kW pump unit and high-performance controllers to ensure and smooth operation.

With electric power steering(EPS) and the multi-functional handle, it works efficiently and safely and confers a comfortable driving experience.

The compact body design of the PT20Li offers a smaller turning radius and requires a smaller aisle width than comparable pallet trucks, making it more suitable for use in confined areas. The lifting system with adjustable pull rods provides greater strength and operation stability.



High performance Li-ion battery

Comparison of Lithium Battery & Lead-Acid Battery

Model	Lithium battery	Lead-acid batteries
Cycle life	2000-4000cycles	300-500cycles
Safe	Green and pollution-free	corrosion, pollution
Charging time	<2h	Above 8h
Power conversion rate	Power conversion rate >97%	Power conversion rate ≤80%
Volume	Small size: 2/3 of the volume of lead-acid batteries	Big
Weight	Light weight: 1/3-1/4 of lead-acid batteries	heavy
Maintenance-free	Maintenance free	Distilled water or acid solution needs to be added regularly
Powerful	Stable voltage output, low self-weight, strong power	The voltage in the first half is high, the voltage in the second half is low, and the power is attenuated when the voltage is low
Memory effect	No memory effect, can be charged and discharged at any time	Has memory (affects battery life)



FAST CHARGING *Efficiency First*

The unique fast-charging feature of lithium batteries makes them an ideal choice for multi-shift operation. On comparison with lead-acid batteries, the lithium batteries show greater performance as they can be charged between operations and during breaks, through the support of opportunity charging, the effective working time of equipment with lithium battery can be prolonged without necessity to replace the battery. Additionally, the opportunity charging has no effect on lithium battery, there is no memory effect and fast consecutive capacity reduction as it is the case for lead-acid batteries.

ENVIRONMENT-FRIENDLY *Strong Versatility*

Lithium batteries are completely sealed, there is no evaporation of electrolyte, forming of explosive gases and chemical smell during charging process. Therefore, the lithium batteries are ideal for use in applications with environmental concerns, such as food processing, chemical and pharmaceutical industries.

SAFETY *High Reliability*

The lithium battery is using LiFePO₄ chemistry (LFP), which is stable and safe. Each battery is equipped with integrated Battery Management System (BMS), which controls various parameters of the cells during charging and discharging operations making the use of lithium batteries safe, reliable and long lasting.



Fast, efficient and flexible



Reliable and ergonomically designed multi-functional handle, each button can be easily reached and controlled, which makes driving more comfortable.



The Multi-functional LCD indicator displays the information about remaining battery power, amount of working hours and fault codes.

Built-in USB port for charging other devices.



The PIN-code lock can be set with multiple passwords and also supports RFID card activation.

Easy maintenance



The lifting system with adjustable pull rods provides greater strength and operation stability.

PT 20Li

- Powerful Drive
- Dual hydraulic cylinders
- 2,2kW pump unit
- High-level controller

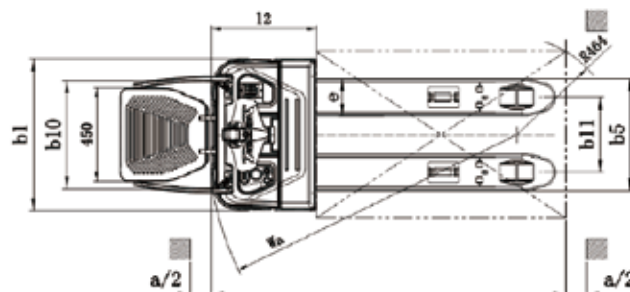
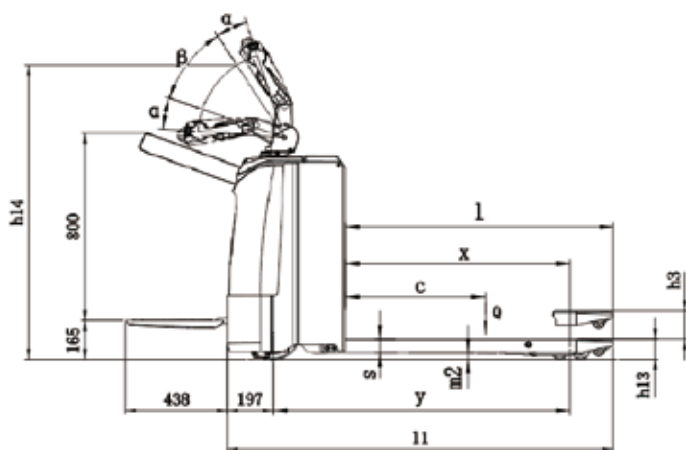

Type sheet for industrial truck acc. to VDI 2198 1KG=2.2LB 1INCH=25.4MM

Identification

1.2	Model		PT20Li
1.3	Drive		Electric
1.4	Operation		Pedestrian/Stand
1.5	Load capacity/rated load	Q (t)	2.0
1.6	Load centre distance	c (mm)	600
1.8	Load distance	x (mm)	899 ¹⁾
1.9	Wheelbase	y (mm)	1206 ¹⁾

Weights

2.1	Net weight with battery	kg	505
2.2	Axle loading,laden front/rear	kg	695/1810
2.3	Axle loading,unladen front/rear	kg	385/120

Wheels/frame

3.1	Tyres		PU
3.2	Tyre size,front	Øxw(mm)	Ø230×70
3.3	Tyre size,rear	Øxw(mm)	Ø82×82
3.4	Additional wheels(dimensions)	Øxw(mm)	Ø100×40
3.5	Wheels,number front/rear(x=driven wheels)		1x+2/2 or 4
3.6	Tread width,front	b10 (mm)	520
3.7	Tread,width,rear	b11 (mm)	360

Basic dimensions

4.4	Lift	h3 (mm)	120
4.9	Height of tiller	h14 (mm)	1070/1260
4.15	Height,lowered	h13 (mm)	85
4.19	Overall length	l1 (mm)	1655
4.20	Length to face of forks	l2 (mm)	505
4.21	Overall width	b1 (mm)	730
4.22	Fork dimensions	s/e/l (mm)	60/180/1150
4.25	Width across forks	b5 (mm)	540/685
4.32	Ground clearance(centre of wheelbase)	m2 (mm)	25
4.34	Aisle width for pallets 800×1200 lengthways	Ast (mm)	2086 ¹⁾
4.35	Turning radius	Wa (mm)	1422 ¹⁾

Performance data

5.1	Travel speed laden/unladen	km/h	7/8
5.2	Lift speed,laden/unladen	mm/s	50/60
5.3	Lowering speed,laden/unladen	mm/s	100/80
5.8	Max. gradeability,laden/unladen	%	8/15
5.10	Service brake		regenerative

Electrisc

6.1	Drive motor,output at S2 60min	kW	1.4
6.2	Lift motor,output at S3 10%	kW	2.2
6.3	Battery as per DIN 43531/35/36 A, B, C, no		no
6.4	Battery voltage/nominal capacity	V/Ah	24/150
6.5	Battery weight	kg	80
6.6	Energy consumption as per EN 16796	KWh/h	0.45

Misc

8.1	Type of drive control		AC-speed control
8.4	Sound pressure level at operator's ear as per EN12053	dB(A)	<70
8.6	Steering		Electric steering

1) 、 Elevated initial lift,lowered initial lift +66mm.